

VINYL-PRO

WINDOW SYSTEMS INC.



Vision of the way window should be





Content:

We welcome you to imagine the world of luxury	2
Let Vinyl-Pro make your home look elegant yet energy saving	3
Casement	4
A Closer Look of Vinyl Construction	5
Roto Casement Corner Drive System.....	6
Roto HG06 High Performance Hinge	7
Awning	8
Awning Cross Section	9
Picture Windows	10
Fixed Casements	11
Single Slider	12
Single Hung	13
End Vent Slider	14
Double Slider	15
Double Hung	16
Window Grids.....	17
Cardinal Architectural Glass LOE 180	18/19
Cardinal Architectural Glass LOE2 272	20/21
Cardinal Architectural Glass LOE3 366	22/23
LOE i89 Glass	24
Glass Options.....	25
Super Spacer.....	26
Super Spacer - You want to do your part,	27
Paint and Stain Options.....	28
Protective Packaging for colour windows	29
Interior Finishes	30
Exterior Finishes	31
Our Manufacturing Facility	32
Our Showroom	33
What is Condensation?	34
Maintenance Manual	35

We welcome you to imagine the world of luxury that Vinyl-Pro can create for your home

Whether you are thinking of renovating or building, Vinyl-Pro will provide you not only with superior energy efficient windows but also with esthetically beautiful product that will greatly improve curb appeal of your house.

From sliders to casements, we offer a wide variety of colours and styles that will complement any house.

Vinyl-Pro windows are built to exceed the highest industry standards and are backed by a LIFETIME warranty. Our products are not mass produced but rather each individual window is crafted with care.

Let Vinyl-Pro make your home look elegant yet energy saving

Benefits

Vinyl-Pro windows will reduce your energy costs for year to come. Our window frames and sashes are fusion welded for strength and durability that provides permanent air and water tight sealing.

Extrusion is made of 100% lead-free uPVC – an environmentally friendly manufacturing process. Our windows are crafted by people who care, using the finest materials and the most recent technology.

All glass units used in our windows have either double or triple glaze insulated with either argon or krypton gas and lowE coating. For easy operation, exceptional style and durability, our windows are equipped with Truth Hardware™. High strength fiberglass screen mesh is standard for improved lifetime.

Investment

Vinyl-Pro windows are the best investment for your home, they are crafted by people who care, built with the finest materials and the most up to date technology available.

Vinyl-Pro windows will earn your trust and confidence by providing you with the industry leading lifetime warranty. So enjoy the elegance and comfort they bring.





Casement

Casement

Casement windows offer a broad, unobstructed view as well as an excellent airflow. Vinyl-Pro's classic white vinyl frame complements any home décor. Highly weather-tight to provide superior energy efficiency with triple sealed.

This window swings open to a full 90° for maintenance and easy cleaning from inside of your house.



A Closer Look of Vinyl Construction

Vinyl-Pro windows are made from an exclusive, 100% lead-free uPVC powder compound. This special compound provides our window systems with a better resistance to impact and discolouration. It ensures that they will not crack, blister or warp, while remaining maintenance free.

Jamb extension
A choice of maintenance free PVC jamb extensions, frame moldings and corner blocks are available to enhance inside finished.

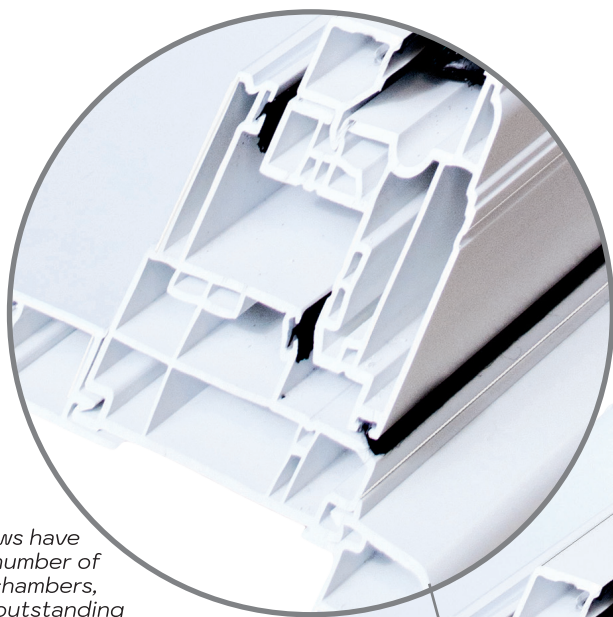

These windows have the highest number of internal air chambers, giving them outstanding insulation and sound abatement qualities, as well as thermal efficiency and increased sturdiness.

Inside trim

Additional Features:

- Opening mechanism and high-security multipoint locking system come with stainless steel hinges and tracks.
- Hardware mounting is done through a minimum of two uPVC frame walls for secure and durable fastening. Depending on the model, casements open at a full 90.°

Fusion welding corners provide attractive appearance & eliminate the need for adhesive and sealants. There are no imperfections on the completely watertight and airtight surface. Internal walls are also welded for increased overall structural strength.

Sealed glass unit has 13/16" overall thickness. Depending on the model, glazing of different types and thicknesses can be applied, including single, double, triple and Low-E glazing as well as a glazed decorative panel (3/4" to 1-1/8")



Roto Casement Corner Drive System

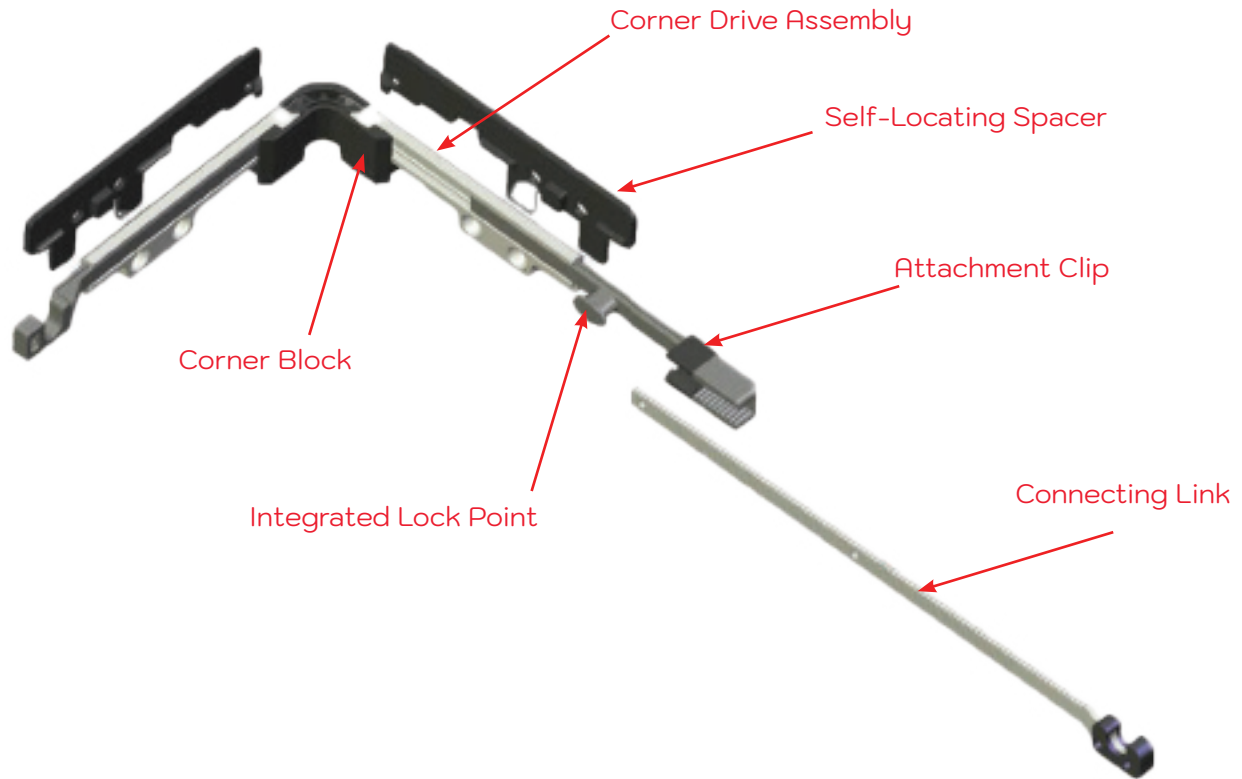

Roto CCD

- Innovative product that offers enhanced security and superior performance through an integrated lock point positioned 3" from the corner and secured to the window frame
- Ensures consistent locking at the top corner of the window, regardless of the window height. This is typically the weakest area in structural and air infiltration tests
- Offers enhanced security and performance of DP100 or higher
- Connects directly to Roto's LB06/LB08 lock bar assembly

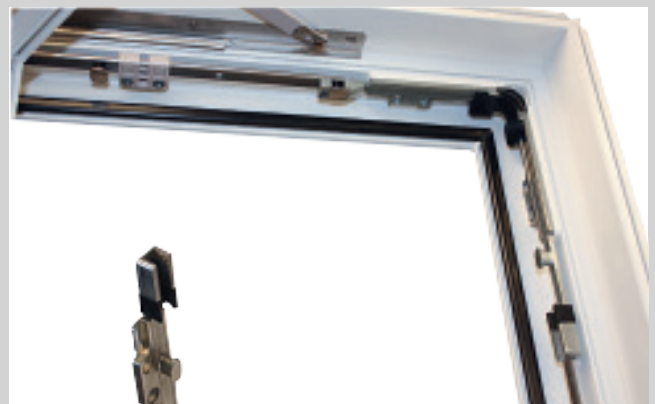



Casement Hinges

HG06 High Performance Hinge



Features & Benefits

- 304 Stainless steel grade hinges
- Premium hinge (14" variant) accommodates sashes up to 125 lbs. (57 kg)
- Low friction materials in track and shoe allows sash to glide smoothly and efficiently
- Fits common 7/16" cavity available in most windows
- Flared track entrance promotes easy sash assembly
- Suitable for most casement window application (wood, vinyl, aluminum, and fiberglass)



Awning



Awning

Vinyl-Pro's awning windows can be installed stand-alone to create a dramatic effect. They can also be used in combination with our fixed windows to build a truly graceful picture window.

Our awning windows have the same energy-saving properties and quality features as much as our Casement windows.

Awning Cross Section

Sealed glass unit has 13/16" overall thickness.
Depending on the model, glazing of different
types and thicknesses can be applied,
including single, double, triple and Low-E
glazing as well as a glazed decorative panel
(3/4" to 1-1/8")

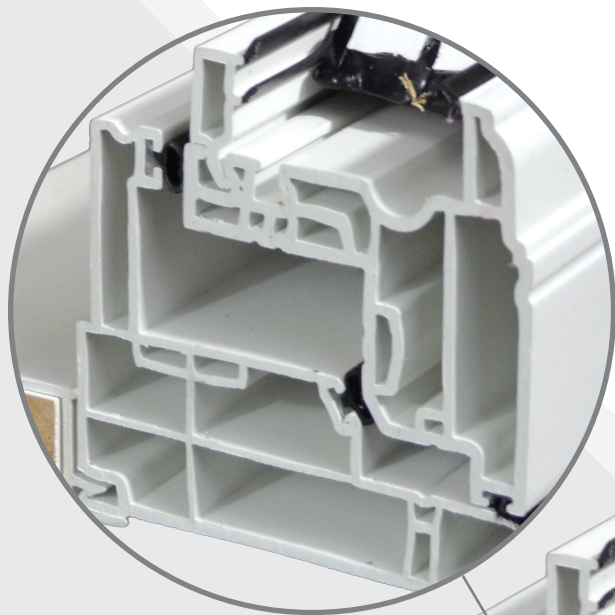

Wood jamb extension with
3/4" wood return



Triple Glass unit 1-3/8"
outside thickness



Picture Window



Picture

Vinyl-Pro offers you maximum versatility in window design through customized picture window frame shapes. Our picture models can function as stand-alone windows or can be used in combination with our fixed, casement, double-hung or single-slider windows.

Fixed Casement (high profile)

Non-opening, fixed windows are the ideal solutions when you wish to create a broad expanse of windows in your home. Large mid-section and two vertical side sections allow a panoramic view while providing a sturdy frame.

Vinyl-Pro's fixed windows offer all the features and craftsmanship found in our other models



Fixed Casements





Single Slider



Single Slider

The most practical and affordable window styles. Manufactured by Vinyl-Pro for maximum elegance and energy efficiency. Our Insta-Lok shoe allows sash to slide effortlessly to let fresh air in. This window has an option to either tilt-in or lift-out for maintenance and easy cleaning. It comes with half screen.

Single Hung

Popular and practical windows make more visually appealing through Vinyl-Pro's clean, classic styling, durable and energy-efficient vinyl. Some spiral sash balance system as double hung model lets you safely clean both sides of the glass from the inside. It comes with half size screen.



Single Hung





End Vent Slider



End Vent Slider

End Vent Slider is an often selected option when a sliding window is preferred but the opening is wider than 72". It is also the window of choice in new construction when the builder wants to achieve the look of a casement window combination at a more economical price. The end vent slider has operating sashes at either end that can be tilted in for easy cleaning from inside of your home.



Double Slider

The ideal choice for areas of the home that require excellent ventilation. Innovative Insta-Lok shoe lets sash glide the full length of the window smoothly and securely. Cleaning from inside is a breeze. Comes with full-length screen.

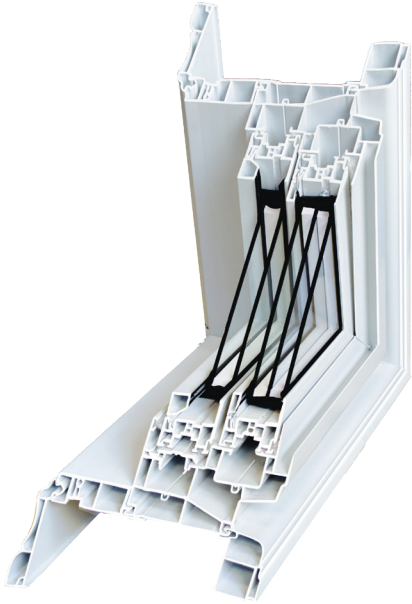

Double Slider





Double Hung



Double Hung

The classic window style found in many areas in most homes. Made more elegant by Vnyl-Pro's tasteful design touches. Efficient spiral sash balance system holds it securely in any position, letting you clean the exterior from the inside. Full size screen allows ventilation from top to bottom.

Window Grids

The use of creative window grids can make a standard window look extraordinary special. Today's homeowners prefer the look of internal grids in their windows to complement the architectural style of their home. Internal grids, inside the insulated glass unit, add style and eliminate cleaning. We provide a wide selection of patterns, finishing and colours to choose from..

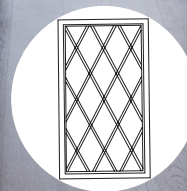
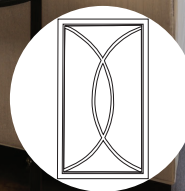
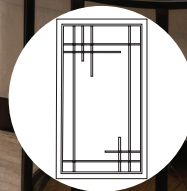
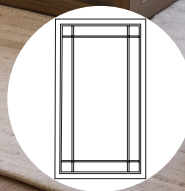
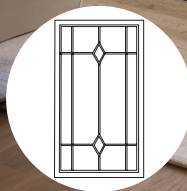
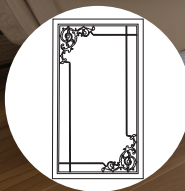

Specialty Shapes

Specialty shapes can make your home look more unique and special. It comes in different shapes, from styles like Half-round to Octagone. Every product is custom made to the exact sizes specified.

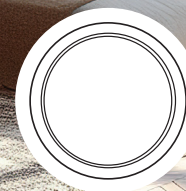
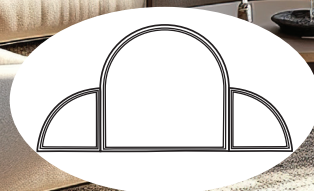
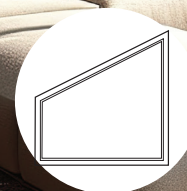

Cardinal Architectural Glass

LoE 180

Realize All the Benefits of High Solar Gain Glass. LoE-180 is the perfect cold remedy. Ideal for passive solar applications, it allows winter sun's heat to pass into the building while blocking heat loss to the outside. In a double-pane unit with argon fill, Cardinal LoE-180 glass delivers an ER of 45, U-factor of 0.26 and visible light transmission of 77%.

This means high levels of cold weather comfort for occupants. What's more, the warmer indoor glass surface means relative humidity can be controlled and maintained properly, improving occupants' comfort and surroundings. Building owners and/or managers benefit from significant energy savings. And because LoE-180 transmits more natural light, architects may be able to reduce lighting loads, resulting in even more savings. Naturally saving energy is also good for the environment.

Cardinal LoE-180 glass can be supplied in stock sheets and can be tempered and laminated for stock delivery. Maximum stock sheet size: 96"x144" (2.43 meters x 3.65 meters).

Cardinal LoE Glass Sets the Standard for Energy-Efficient Glass. Our patented, state-of-the-arts pattered coatings are unmatched by any other glass manufacturer. These high-transmission coatings are virtually clear, blocking the heat and reducing solar gain, while optimizing light transmission. In fact, our LoE2 and LoE3 coatings actually out perform tinted glass often used.

Cardinal produces nearly 700 million square feet of coated glass annually, at seven coating plants across the U.S. Our Intelligent Quality Assurance Program (I.Q.) ensures the quality of every piece of glass. Using our patented inspection systems, we thoroughly examine the glass for exterior and room side color, visible transmission/reflection, IR reflection and edge deletion.

Cardinal LoE-180 Delivers Outstanding Thermal Performance.

	Unit Make Up			Visible Light			Solar Energy					U Factor - Air				U Factor - Argon				ER*
	Exterior Lite	Airspace	Inboard Lite	Transmissio	Reflectance		SHGC	SC	LSG	RHG	BTU/Hr.ft²°F		W/m²°K		BTU/Hr.ft²°F		W/m²°K			
					Exterio	Interior					Summe	Winter	Summer	Winter	Summer	Winter	Summer	Winter		
6mm	Clear	13mm	Clea	80%	15%	15%	0.72	0.83	1.11	172	542	0.49	0.47	2.81	2.68	0.47	0.45	2.69	2.55	26
	LoE180(#2)	13mm	Clea	77%	15%	14%	0.60	0.69	1.28	142	447	0.28	0.30	1.60	1.72	0.23	0.26	1.32	1.47	43
	Clear	13mm	LoE180(#3)	77%	14%	15%	0.64	0.73	1.20	150	474	0.28	0.30	1.60	1.72	0.23	0.26	1.32	1.47	45

*These values are based on center of glass numbers assuming no air flow.

Performance Characteristics vs. Clear Glass

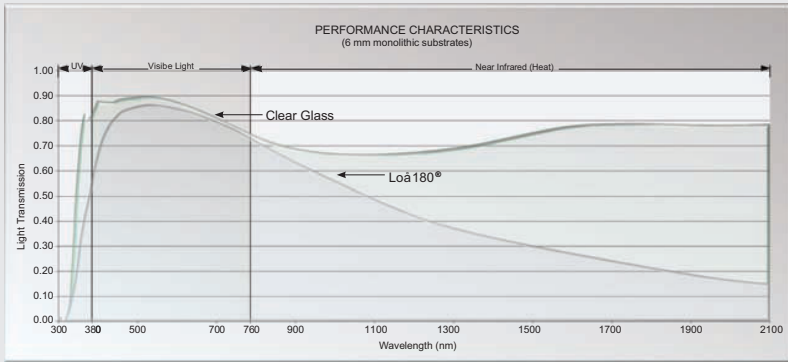

How to Use the Wind Load Chart and Design Factors:

- Locate the long dimension and short dimension on the chart.
- Draw a vertical line from the long dimension and a horizontal line from the short dimension.
- At the point where these lines intersect, interpolate between the wind load (kPa) contours to determine the allowable wind load. For windload in PDF, use the conversion factor in chart.
- If the glass construction other than annealed-annealed is to be used, determine the wind load for the annealed-annealed glass with the appropriate glass thickness, and multiply this wind load by the appropriate load factor (see Load Factors).

Load Factors

Annealed-Annealed	1.0
Heat Strengthened-Annealed	1.11
Heat Strengthened-Heat Strengthened	2.0
Heat Strengthened-Tempered	2.11
Tempered-Tempered	6.0

Transmitted and Exterior Appearance of Clear vs. LoE-180 Glass.

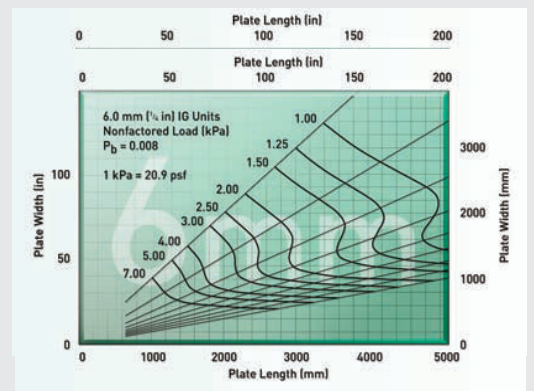
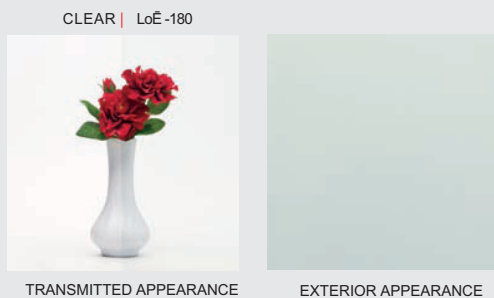

775 Prairie Center Drive
Eden Prairie, MN55344
cardinalcorp.com

Cardinal Glass Industries is considered one of the world's leading providers of superior quality glass products. From the melting of sand to produce clear float glass to the vacuum sputtering of silver to produce low-emissivity coatings, Cardinal manufactures the quality components and finished insulating glass products used in top-of-the-line buildings around the world.

Cardinal Architectural Glass

LoE²
272

Get Superior Thermal Performance Year Around.

LoE²-272 is ideal for any climate, any weather. Just look at the numbers. In a double-pane unit with argon fill, Cardinal LoE²-272 glass delivers an SHG C of 0.40, U-factor of 0.25 and visible light transmission of 70%. All with no haze or bluish cast.

This means high levels of year-round comfort for occupants. What's more, the warmer indoor glass surface means relative humidity can be controlled and maintained properly, improving occupants' comfort and surroundings. Building owners and/or managers benefit from significant energy savings. And because LoE²-272 transmits more natural light and reduces solar gain, architects may be able to reduce lighting and air conditioning loads, resulting in even more savings. Naturally saving energy is also good for the environment.

Cardinal LoE²-272 glass can be supplied in stock sheets and can be tempered and laminated for stock delivery. Maximum stock sheet size: 96"x144" (2.43 meters x 3.65 meters).

Cardinal LoE Glass Sets the Standard for Energy-Efficient Glass. Our patented, state-of-the-art pattered coatings are unmatched by any other glass manufacturer. These high-transmission coatings are virtually clear, blocking the heat and reducing solar gain, while optimizing light transmission. Infact, our LoE² and LoE³ coatings actually outperform tinted glass often used.

Cardinal produces nearly 700 millions quare feet of coated glass annually, at seven coating plants across the U.S. Our Intelligent Quality Assurance Program (I.Q.) ensures the quality of every piece of glass. Using our patented inspection systems, we thoroughly examine theglass for exterior and room side color, visible transmission/reflection, IR reflection and edge deletion.

Cardinal LoE²-272 Delivers Outstanding Thermal Performance.

	Unit Make Up			Visible Light			Solar Energy				U Factor - Air				U Factor - Argon				
	Exterior Lite	Airsapc	Inboard Lite	Transmissio	Reflectance		SHGC	SC	LSG	RHG	BTU/Hr.ft ² F		W/m ² K		BTU/Hr.ft ² F		W/m ² K		
					Exterior	Interior					Summer	Winter	Summer	Winter	Summer	Winter	Summer	Winter	
6mm	Clear	13mm	Clear	80%	15%	15%	0.72	0.83	1.11	172	542	0.49	0.47	2.81	2.68	0.47	0.45	2.69	2.55
	LoE ² 272 [®]	13mm	Clear	70%	10%	11%	0.40	0.46	1.75	95	300	0.27	0.29	1.54	1.67	0.22	0.25	1.25	1.41
	Arctic Blue	13mm	LoE ² 272 [®]	41%	7%	9%	0.28	0.32	1.47	67	212	0.27	0.29	1.54	1.67	0.22	0.25	1.25	1.41
	Evergreen	13mm	LoE ² 272 [®]	51%	8%	9%	0.30	0.34	1.72	71	224	0.27	0.29	1.54	1.67	0.22	0.25	1.25	1.41
	Blue-Green	13mm	LoE ² 272 [®]	59%	9%	10%	0.37	0.42	1.61	88	276	0.27	0.29	1.54	1.67	0.22	0.25	1.25	1.41
	Bronze	13mm	LoE ² 272 [®]	40%	7%	9%	0.31	0.36	1.27	75	238	0.27	0.29	1.54	1.67	0.22	0.25	1.25	1.41

Performance Characteristics vs. Clear Glass

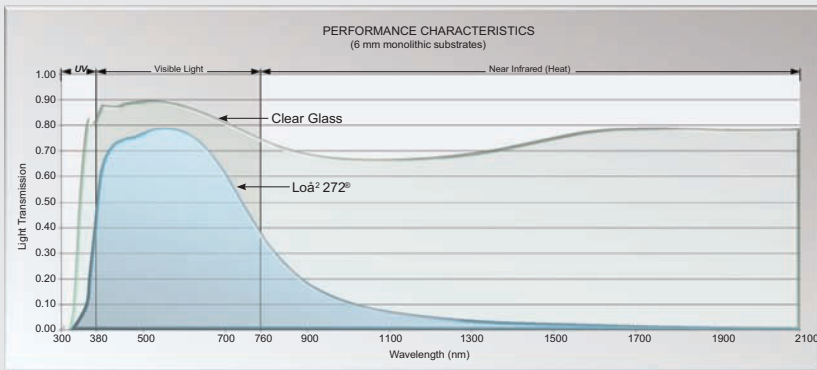

How to Use the WindLoad Chart and Design Factors:

- Locate the long dimension and short dimension on the chart.
- Draw a vertical line from the long dimension and a horizontal line from the short dimension.
- At the point where these lines intersect, interpolate between the wind load (kPa) contours to determine the allowable wind load. For windload in PDF, use the conversion factor in chart.
- If the glass construction other than annealed-annealed is to be used, determine the wind load for the annealed-annealed glass with the appropriate glass thickness, and multiply this wind load by the appropriate load factor (see Load Factors).

Load Factors

Annealed-Annealed	1.0
Heat Strengthened-Annealed	1.11
Heat Strengthened-Heat Strengthened	2.0
Heat Strengthened-Tempered	2.11
Tempered-Tempered	6.0

Transmitted and Exterior Appearance of Clear vs. LoE²-272 Glass.

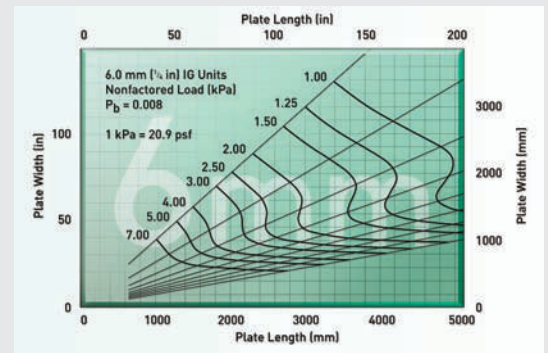
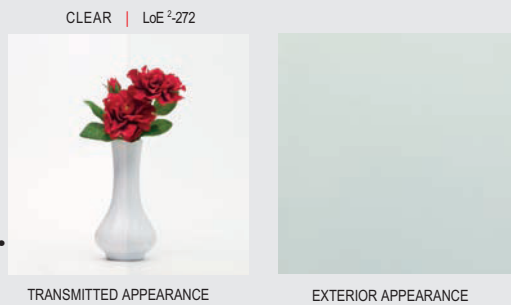

Cardinal Glass Industries is considered one of the world's leading providers of superior quality glass products. From the melting of sand to produce clear float glass to the vacuum sputtering of silver to produce low-emissivity coatings, Cardinal manufactures the quality components and finished insulating glass products used in top-of-the-line buildings around the world.

Cardinal Architectural Glass

LoE³
366

Get the Perfect Balance of Solar Control and High Visibility. Just look at the numbers. In a double-pane unit with argonfill, Cardinal LoE³-366 glass deliver an SHGC of 0.27, U-factor of 0.24 and visible light transmission of 63%. All with no interior-darkening tints and virtually no exterior reflectance.

This means a high level of year-round comfort for occupants. What's more, the warmer indoor glass surface means relative humidity can be controlled and maintained properly, improving occupants' comfort and surroundings.

Building owners and/or managers benefit from significant energy savings. And because LoE³-366 transmits more natural light and reduces solar gain, architects may be able to reduce lighting and air conditioning loads, resulting in even more savings. Naturally saving energy is also good for the environment.

Cardinal LoE³-366 glass can be supplied in stock sheets and can be tempered 3 and laminated for stock delivery. Maximum stock sheet size: 96" x 144" (2.43 meters x 3.65 meters).

Cardinal LoE Glass Sets the Standard for Energy-Efficient Glass. Our patented, state-of-the-art pattered coatings are unmatched by any other glass manufacturer. These high-transmission coatings are virtually clear, blocking the heat and reducing solar gain, while optimizing light transmission. In fact, our LoE² and LoE³ coatings actually outperform tinted glass of ten used.

Cardinal produces nearly 700 million square feet of coated glass annually, at seven coating plants across the U.S. Our Intelligent Quality Assurance Program (I.Q.) ensures the quality of every piece of glass. Using our patented inspection systems, we thoroughly examine the glass for exterior and room side color, visible transmission/reflection, IR reflection and edge deletion

Cardinal LoE³-366 Delivers Outstanding Thermal Performance.

	Unit Make Up			Visible Light			Solar Energy				U Factor - Air				U Factor - Argon				
	Exterior Lite	13mm	Lite	Transmission	Reflectance		SHGC	SC	LSG	RHG	BTU/Hr.ft. ² °F		W/m ² °K		BTU/Hr.ft. ² °F		W/m ² °K		
					Exterior	Interior					Summer	Winter	Summer	Winter	Summer	Winter	Summer	Winter	
6mm	Clear	13mm	Clear	80%	15%	15%	0.72	0.83	1.11	172	542	0.49	0.47	2.81	2.68	0.47	0.45	2.69	2.55
	Lo ^a 3 366 [®]	13mm	Clear	63%	11%	11	0.27	0.31	2.33	65	205	0.26	0.29	1.48	1.65	0.20	0.24	1.14	1.36
	Arctic Blue	13mm	Lo ^a 3 366 [®]	37%	7%	9%	0.24	0.28	1.54	59	186	0.26	0.29	1.48	1.65	0.20	0.24	1.14	1.36
	Evergreen	13mm	Lo ^a 3 366 [®]	46%	8%	10%	0.27	0.31	1.70	64	202	0.26	0.29	1.48	1.65	0.20	0.24	1.14	1.36
	Blue-Green	13mm	Lo ^a 3 366 [®]	53%	9%	10%	0.32	0.37	1.66	76	240	0.26	0.29	1.48	1.65	0.20	0.24	1.14	1.36
	Bronze	13mm	Lo ^a 3 366 [®]	37%	7%	10%	0.26	0.30	1.42	62	196	0.26	0.29	1.48	1.65	0.20	0.24	1.14	1.36

Performance Characteristics vs. Clear Glass

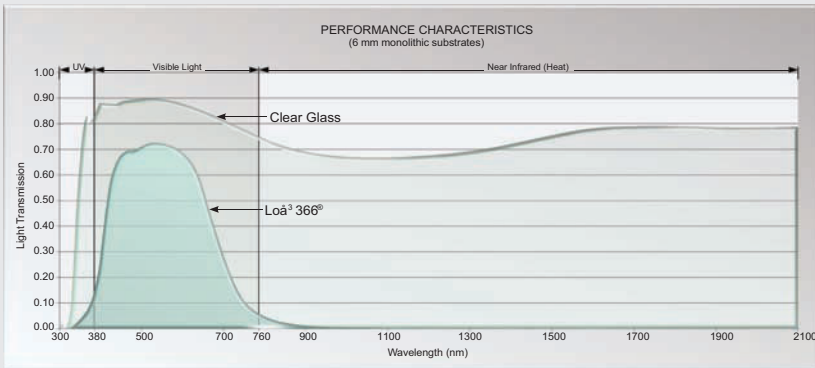

How to Use the Wind Load Chart and Design Factors:

- Locate the long dimension and short dimension on the chart.
- Draw a vertical line from the long dimension and a horizontal line from the short dimension.
- At the point where these lines intersect, interpolate between the wind load (kPa) contours to determine the allowable wind load. For windload in PDF, use the conversion factor in chart.
- If the glass construction other than annealed-annealed is to be used, determine the wind load for the annealed-annealed glass with the appropriate glass thickness, and multiply this wind load by the appropriate load factor (see Load Factors).

Load Factors

Annealed-Annealed	1.0
Heat Strengthened-Annealed	1.11
Heat Strengthened-Heat Strengthened	2.0
Heat Strengthened-Tempered	2.11
Tempered-Tempered	6.0

Transmitted and Exterior Appearance of Clear vs. LoE³-366 Glass

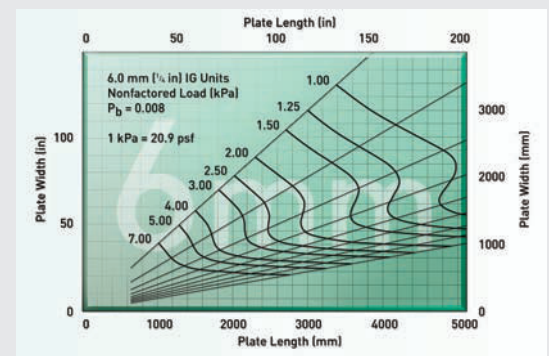
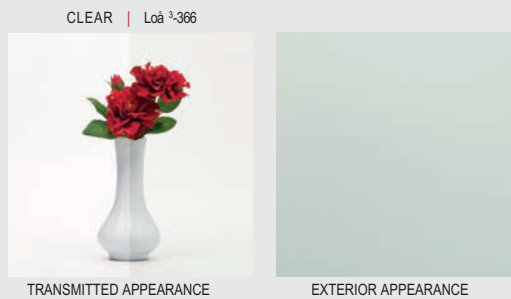

Cardinal Glass Industries is considered one of the world's leading providers of superior quality glass products. From the melting of sand to produce clear float glass to the vacuum sputtering of silver to produce low-emissivity coatings, Cardinal manufactures the quality components and finished insulating glass products used in top-of-the-line buildings around the world.



LoE-i89 Glass

ENHANCED WINTER PERFORMANCE GLASS

Double-pane windows become triple pane performers.

There's no need to go to triple-pane windows to meet the various energy-saving guidelines. No need to invest in redesigning your windows and altering your manufacturing processes either. A double-pane IG unit with LoE-i89 can meet the guidelines.

LoE-i89 is sputtered onto the indoor lite, the #4 surface, thus reflecting escaping heat back into the room and lowering U-Factors. Coupled with our LoE2 or LoE3 glass

and argon fill, this double-pane unit delivers performance much better than clear triple-pane – a centre of glass U-Factor of just 0.20 compared to 0.37 with clear triple-pane.

To surpass the U-Factor performance of our LoE-i89 double-pane unit, you would need to go to a triple-pane unit with a low-E coating in each gap.



GLASS PERFORMANCE

Double Pane with LoE-i89

IG TYPE AND COATING	VISIBLE LIGHT			FADE TRANSMISSION		SOLAR	U-FACTOR IP / SI	
	TRANSMITTANCE	EXTERNAL REFLECTANCE	INTERNAL REFLECTANCE	UV	ISO	HEAT GAIN COEFFICIENT	AIR FILL	ARGON FILL
LOE-180, LOE-i89	77%	15%	14%	0.27	0.61	0.62	0.24	0.21
LOE-272, LOE-i89	70%	11%	11%	0.16	0.53	0.41	0.23	0.20
LOE-270, LOE-i89	69%	12%	12%	0.14	0.51	0.36	0.23	0.20
LOE-366, LOE-i89	63%	11%	11%	0.05	0.41	0.27	0.23	0.20

7/8" Triple Pane

IG TYPE AND COATING	VISIBLE LIGHT			FADE TRANSMISSION		SOLAR	U-FACTOR IP / SI	
	TRANSMITTANCE	EXTERNAL REFLECTANCE	INTERNAL REFLECTANCE	UV	ISO	HEAT GAIN COEFFICIENT	AIR FILL	ARGON FILL
LOE-180, LOE-i89	70%	20%	20%	0.13	0.50	0.56	0.26	0.20
LOE-272, LOE-i89	63%	15%	18%	0.08	0.44	0.38	0.25	0.20
LOE-270, LOE-i89	62%	16%	19%	0.07	0.43	0.34	0.25	0.20
LOE-366, LOE-i89	57%	14%	18%	0.02	0.36	0.25	0.25	0.20

Clear Glass

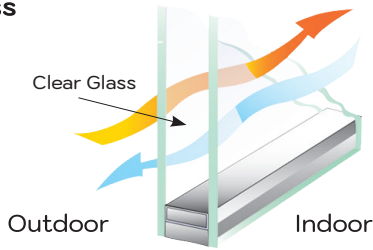

Low-E-Glass

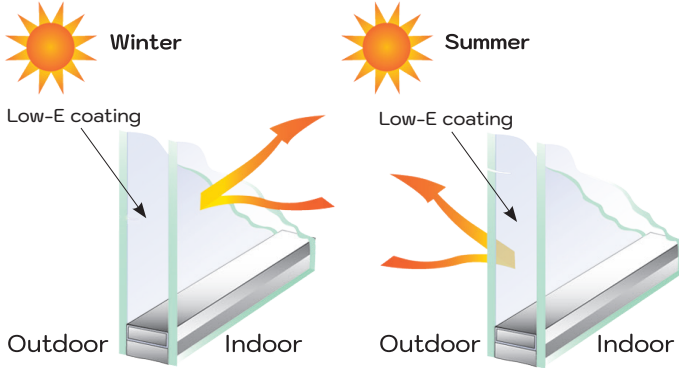

Triple Glass

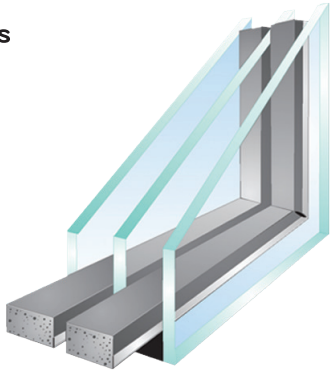

Clear Glass

Clear Glass unit provides more efficiency on noise protection than single pane glass. A clear glass unit allows heat and cold air from both the inside and outside to pass through without resistance.

Low-E Glass

In winter, low-E Glass reduces heat loss to the cold outdoors by dramatically reducing radiant heat transfer and actually reflecting interior heat back into the room. It allows more of the sun's rays to enter a home as solar energy to be converted into usable heat. As in winter, the same effect of keeping interior heat inside, and in summer it helps to reduce the flow of hot outside air into the cooler interior. Therefore, it helps to lower your energy cost all year long. Low-E Glass also reduces transmission of the sun's UV ray which is the leading cause of premature fading and degradation of fabrics & carpeting.

Triple Glass

Triple pane glass windows are the most energy efficient models in the market, due to the extra pane of glass, insulating glasses help keep cold air outside and warm air in, or vice versa. Special coatings are often applied to the glass windows to enhance their energy efficiency by eliminating solar gain.

Glass Options



Super Spacer

*You want to do your part,
We can help*



*Super Spacer.... the winning choice
for the industry's most durable
insulation glass units.*

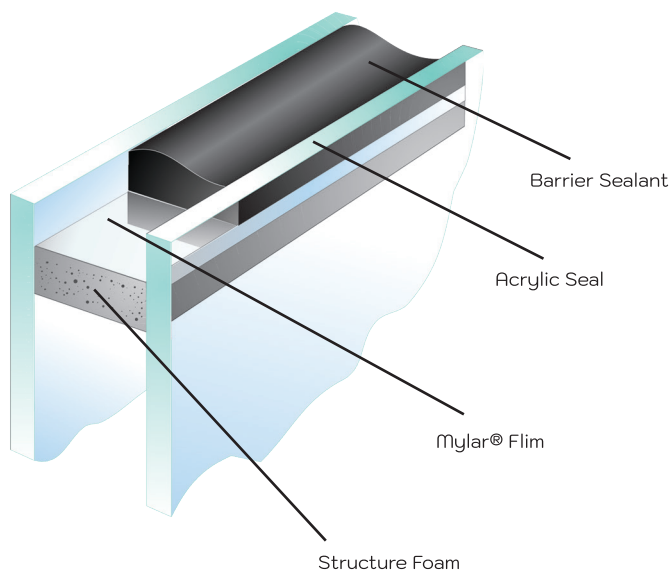

The Product,

Warm edge technology is more than just a low-conductive product that helps make windows more thermally efficient. The warm edge spacer is the actual seal that keeps the glass package in windows from falling.

There are two types of insulating glass systems on the market today: Single seal and dual seal systems. Single seal units are constructed of only one type of sealant, which is called upon to perform double-duty. Not only must the sealant retard the infiltration of moisture vapour, but it must also hold the unit together under a wide variety of both high and low temperatures while withstanding the effects of high humidity and ultra violet exposure.

A dual-seal unit is constructed using a combination of a sealant that functions mainly as a high-strength adhesive and a second sealant, which is used primary as a moisture vapour seal.

Super Spacer® is a dual seal insulating glass system. This No-Metal, structural foam spacer clearly resists condensation, reduces energy costs, provides long-life durability and adds both comfort and value to your windows.

Protect your most precious possessions—choose Health Smart WIndows for your home and family.

*Super Spacer
Reverses dual seal construction*

You want to do your part, We can help

The all-foam formula of Super Spacer® is proven to be less conductive, which can block heat from escaping or entering through the glass edge. It provides optimal thermal performance and is the lowest U-Value in the industry.

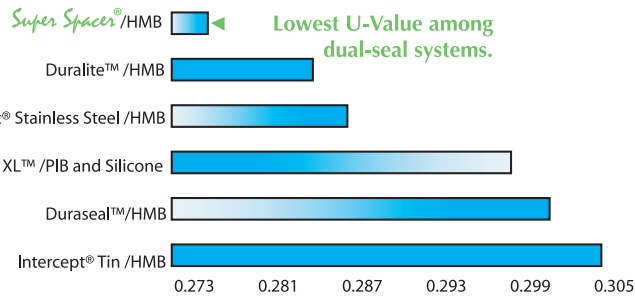

- Optimized energy savings
- Enhanced environmental comfort and health near windows
- Condensation and mold resistance like no other spacer
- Extreme durability for sustainable performance



Super Spacer



Paint & Stain Options

- Vinyl-Pro uses Prolux paint which is a leader in technology and innovative products for liquid paint market. Prolux produces coatings for many different substrates including a superb line of paints formulated exclusively for PVC.
- All our colour window frames are coated with four layers of paint for lighter colour, and six layers for darker colour. While industry standard with two coats for lighter colour and three coats for darker colour are applied.
- Vinyl-Pro offers a wide range of exciting colours to compliment any home improvement project.
- All of our products are painted in boxes instead of in liners.
- All painted frames come with 10 year warranty.
- Vinyl-Pro is one of a few manufacturers that offers on site painting service for minor paint damages during installation.
- Vinyl-Pro also offers a three stage stain for both exterior and interior part of the window to achieve the look of natural wood finishing.



Protective Packaging for colour windows

- All painted frames are protected by protective film from being scratched during installation.
- All painted windows are securely packaged to avoid window from being damaged during transportation.



Protective Film for colour painted windows



Protective Packaging for colour painted windows

Interior Finishes

Vinyl package with classic rosettes

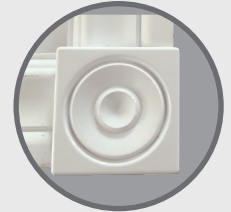

Vinyl package with stepcasting

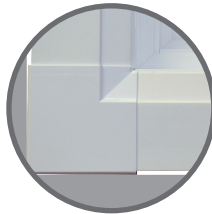

Vinyl package in wood stain finish



Vinyl package with contemporary rosettes



Exterior Finishes



Combination of Casement & Awning with 5/8" brickmould & simulated divided light (SDL) grills



Shape Transom on top of Casement & Fixed Casement combination with 5/8" brickmould



Combination of windows with 2" brickmould



Combination of fixed and casement windows with 1-1/4" brickmould

Our Manufacturing Facility

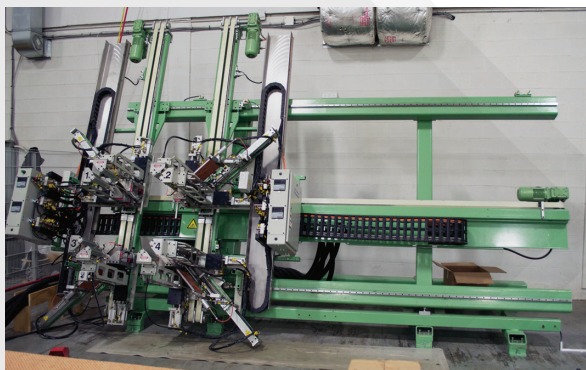

- All our vinyl windows are fusion welded with a burn off 1/4" to ensure durability and strength.
- 45° cuts are done with digital precision to provide maximum strength while welding.
- CNC corner cleaning technology eliminates hand scratching of weld lips and provides the best automated finish available in the industry.
- At Vinyl-Pro we also make our own sealed glass thermo units to ensure prompt delivery & quality.

Our Showroom



What is Condensation?



Understanding Condensation on Window

Ever wonder why condensation forms on your windows - and what you can do to prevent it?

Below is a collection of questions and answers designed to provide you with a better understanding of condensation and how you can minimize it.

Exterior condensation questions?

What causes exterior condensation?

Exterior condensation occurs when moist air comes into contact with cool surfaces, such as glass. This type of condensation appears when the dew point in the air is higher than the temperature of the glass. This occurs when a cool night follows a warmer day, most typically during the spring and fall seasons.

How does low-e missivity glass affect exterior condensation?

Low-E glass reduces heat conducted through the glass from the warm interior of the home to the outside glass surface. Heat conduction can be reduced by as much as 50 percent with an efficient Low-E coated glass. This reflected heat energy reduces the outside glass temperature and can result in condensation on the glass. Exterior condensation is actually an indication that the insulating glass in the window is performing as it should.

Interior condensation questions?

What Causes condensation on the inside glass of window?

Whenever there is excess humidity in a home, it manifests itself in the form of condensation on the coldest area of a wall, which is normally the windows. The warmer the air, the more moisture it will retain, so when air in your home comes in contact with the colder glass surfaces, it is subsequently cooled and moisture is released in the form of condensation on the glass.

Do windows cause condensation?

No, condensation on window is not the fault of the window. However, by replacing drafty windows and door or installing a new roof or siding, you are reducing air flow in your home and making it tighter. Tighter homes actually retain more humidity.

Where on a window does condensation normally form and why?

Condensation often forms at the meeting rail and at the bottom of the lower sash on the interior of the glass. This is because when warm air cools, it falls down across the interior surface of the window at the same time the temperature of the air is falling. The air contacts the horizontal surface of the trapped water vapor to escape and form on the meeting rail's surface. The air then rolls over the edge of the meeting rail and again gains speed until it encounters the lower handle of the sash. At this point, the water vapor again makes its exit and lies at the bottom of the sash.

Can I reduce the condensation on my window?

Yes. In order to reduce condensation, humidity must be controlled and air movement must be generated. As the exterior temperature drops, the humidity level needs to decrease if condensation is to be controlled.

What steps can I take to reduce humidity in my house?

The two main things you can do are to control sources of moisture and increase ventilation. To decrease or control excess humidity and condensation:

1. Use exhaust fans in your kitchen, laundry and bathrooms.
2. Vent gas burners, clothes dryers, etc. to the outdoors.
3. Shut off furnace humidifiers and other humidifying devices in your home.
4. Be sure that the ventilating louvers in your attic, basement or crawl spaces are open and amply sized.
5. Open fireplace dampers to allow an escape route for moisture-laden air.
6. Air out your house a few minutes each day.

Maintenance Manual



Normal Maintenance

The uPVC windows only require to be washed with warm soapy water, perhaps when the glass is being cleaned. You should never use any abrasive materials to clean these windows as this will cause scratching, dull the surface and encourage the formation of dirt and stains.

Do not use cleaners containing aggressive organic solvents because they could affect the surface appearance of the vinyl. Examples of such cleaners are: chlorine bleach, liquid grease remover, strong soaps and detergents containing organic solvents, nail polish remover and furniture polish/cleaner.

For WoodGrain Finishes, use mild household cleaners. Do not use harsh abrasive cleaners on these surfaces. Use a Mr. Clean® Magic Eraser® on the hard to clean areas.

Normal Maintenance for Glass

Clean the glass using standard glass cleaner such as Windex®. Do not use abrasive cleaners, as it will scratch the glass. Decals and dried debris can be removed with a new single edged razor blades, wetting the glass first with glass cleaner.

Normal Maintenance of the Screen

To clean the screens, simply hose them off with water. For built-up dirt, you can use a mild soap and sponge, then rinse thoroughly. Do not use aerosol cleaning agents on screens, as certain propellants in the cleaners can cause damage to the molded corner parts.

VISION OF THE WAY WINDOW SHOULD BE



VINYL-PRO
WINDOW SYSTEMS INC.